



515 N. FRALEY STREET
KANE, PA 16735
PH. (814) 837-6464

VAN GUARD II ALUMINUM HURRICANE BARRIER OUTSWING "IMPACT"

GENERAL NOTES

1. This product has been evaluated and is in compliance with the 6th Edition (2017) Florida Building Code (FBC) structural requirements including the "High Velocity Hurricane Zone" (HVHZ).
2. Product anchors shall be as listed and spaced as shown on details. Anchor embedment to base material shall be beyond wall dressing or stucco.
3. When used in the HVHZ, this product complies with Section 1626 of the FBC and does not require an impact resistant covering.
4. Site conditions that deviate from the details of this drawing require further engineering analysis by a licensed engineer or registered architect.
5. All steel shall be protected as specified in Section 2222.6 of the FBC.

TABLE OF CONTENTS	
SHEET #	DESCRIPTION
1	Typical elevation, design pressures & general notes
2	Barrier panel sections, components & screen details
3	Reveal mount sections - masonry wall
4	Surface mount sections - masonry wall
5	Reveal mount sections - 2x wood framing
6	Surface mount sections - 2x wood framing
7	Frame anchoring - masonry wall
8	Frame anchoring - 2x wood framing
9	Bill of materials, components & lock release options

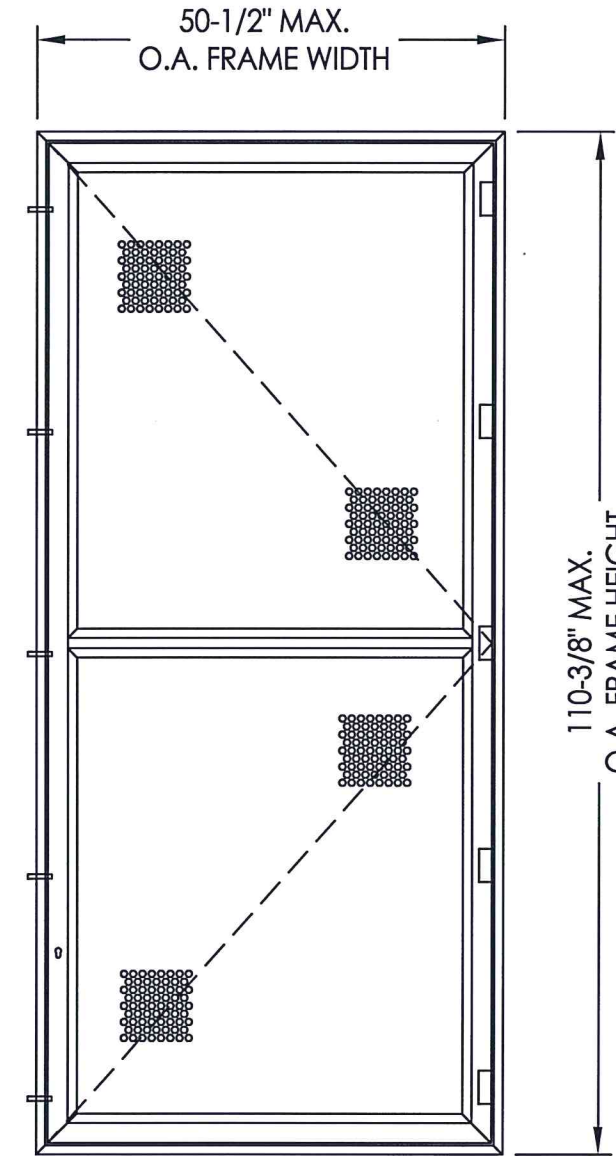

MOUNTING STYLE	OVERALL FRAME DIMENSION	SCREEN OPENING DIMENSION	DESIGN PRESSURE (PSF) (without Porosity Factor)		DESIGN PRESSURE (PSF) (with Porosity Factor*)	
			POSITIVE	NEGATIVE	POSITIVE	NEGATIVE
REVEAL MOUNT	50.50"	41.78"	50.0	50.0	80.0	80.0
SURFACE MOUNT	110.375"	49.18"	50.0	50.0	80.0	80.0

* NOTE: The Design Pressure shown has been increased for the porosity of the barrier (62%). The consideration of the use of the porosity factor is at the discretion of the Design Professional or the Authority Having Jurisdiction.

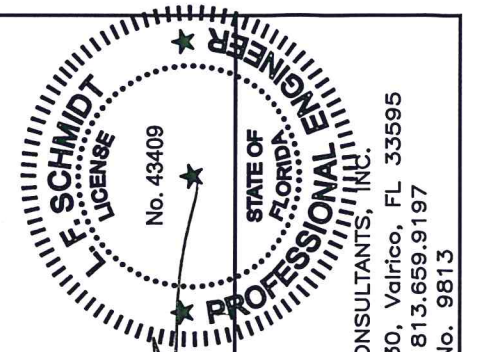

Documents Prepared By:
Lyndon F. Schmidt
P.E. No. 43409

R.W. BUILDING CONSULTANTS, INC.
P.O. Box 230, Valrico, FL 33595
Phone No.: 813.659.9197
FBPE C.A. No. 9813

PRODUCT: KANE SCREENS
VAN GUARD II
ALUMINUM HURRICANE BARRIER
PART OR ASSEMBLY:
TYPICAL ELEVATION, DESIGN PRESSURES & GENERAL NOTES

NO.	DATE	REVISIONS
2	9/26/17	UPDATE TO 6TH ED. (2017) FBC
1	7/01/15	UPDATE TO 5th ED. (2014) FBC

DATE: 11/11/13
SCALE: N.T.S.
DWG. BY: JK
CHK. BY: LFS
DRAWING NO.: FL-10238.3
SHEET 1 OF 9

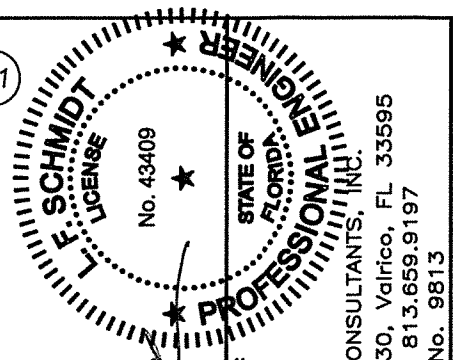
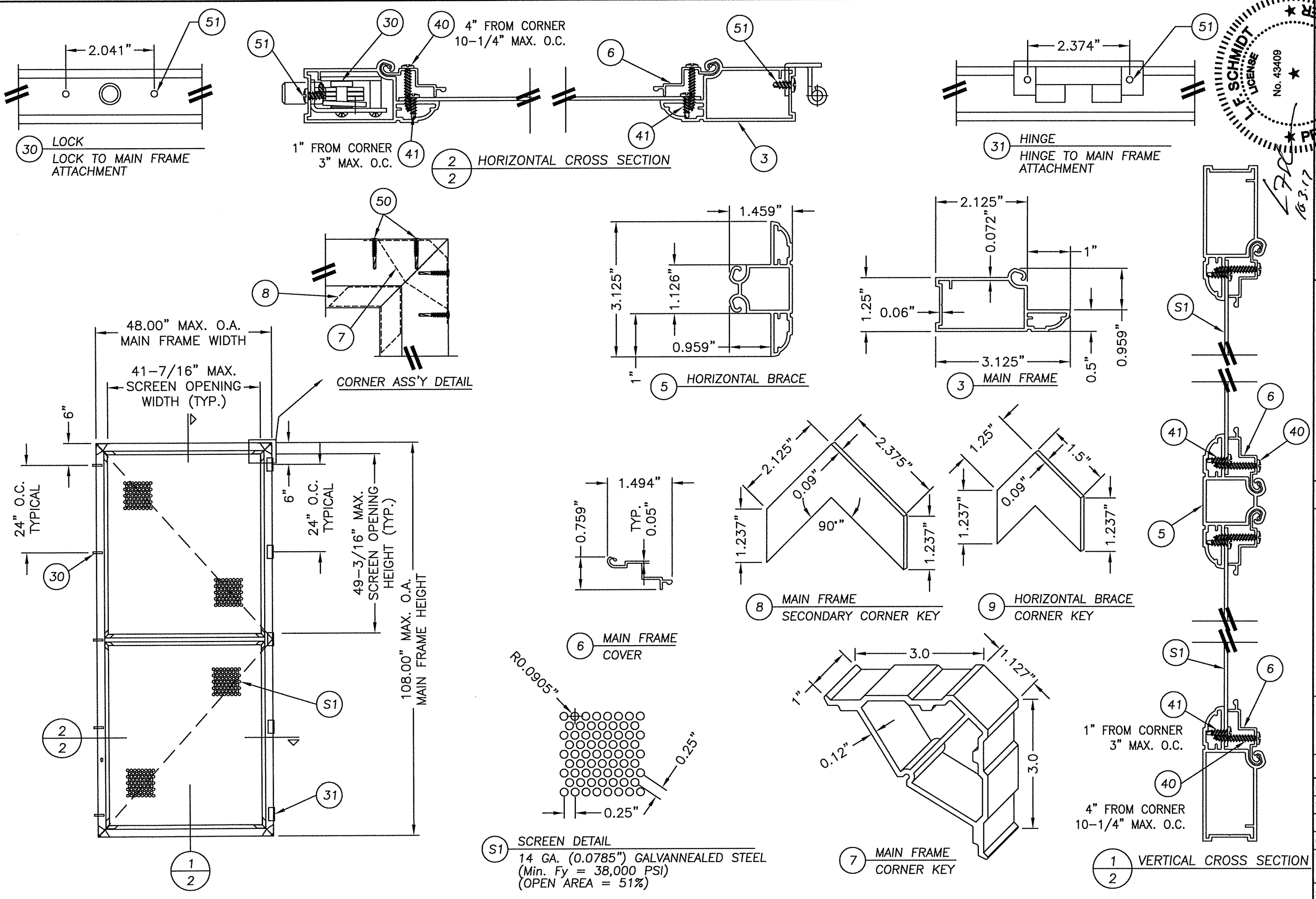

Documents Prepared By:
Lyndon F. Schmidt
P.E. No. 43409

R.W. BUILDING CONSULTANTS, INC.
P.O. Box 230, Valrico, FL 33595
Phone No.: 813.659.9197
FBPE C.A. No. 9813

PRODUCT: KANE SCREENS
VAN GUARD II
ALUMINUM HURRICANE BARRIER
PART OR ASSEMBLY:
BARRIER PANEL SECTIONS,
COMPONENTS & SCREEN DETAILS

NO.	DATE	BY	REVISIONS
2	9/26/17	JK	UPDATE TO 6TH ED. (2017) FBC
1	7/01/15	LFS	UPDATE TO 5TH ED. (2014) FBC

DATE: 11/11/13
SCALE: N.T.S.
DWG. BY: JK
CHK. BY: LFS
DRAWING NO.: FL-10238.3
SHEET 2 OF 9

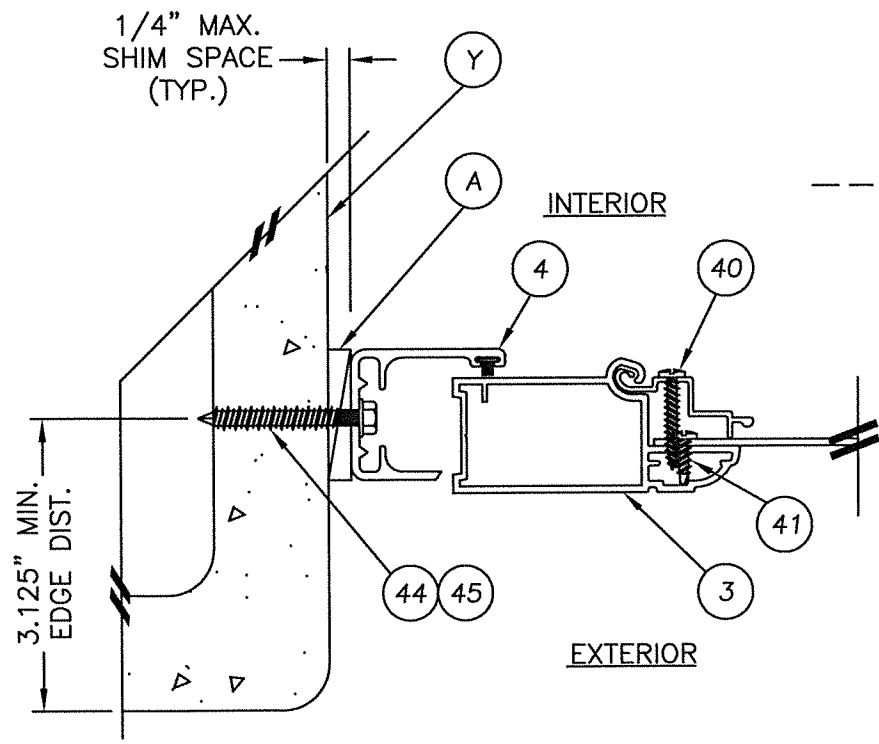

1 REVEAL MOUNT - HINGE JAMB
3 HINGE REMOVED FOR CLARITY

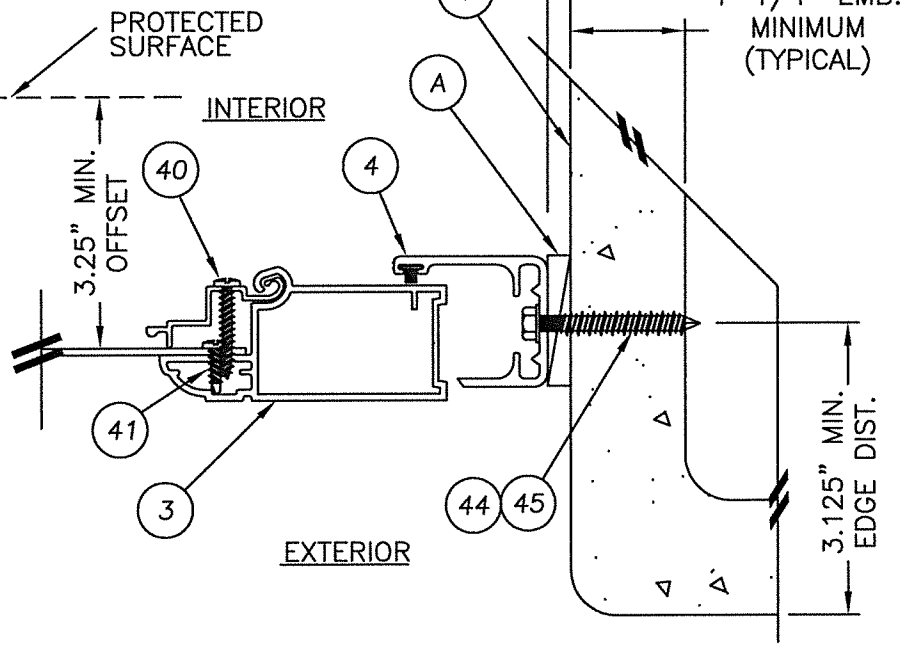
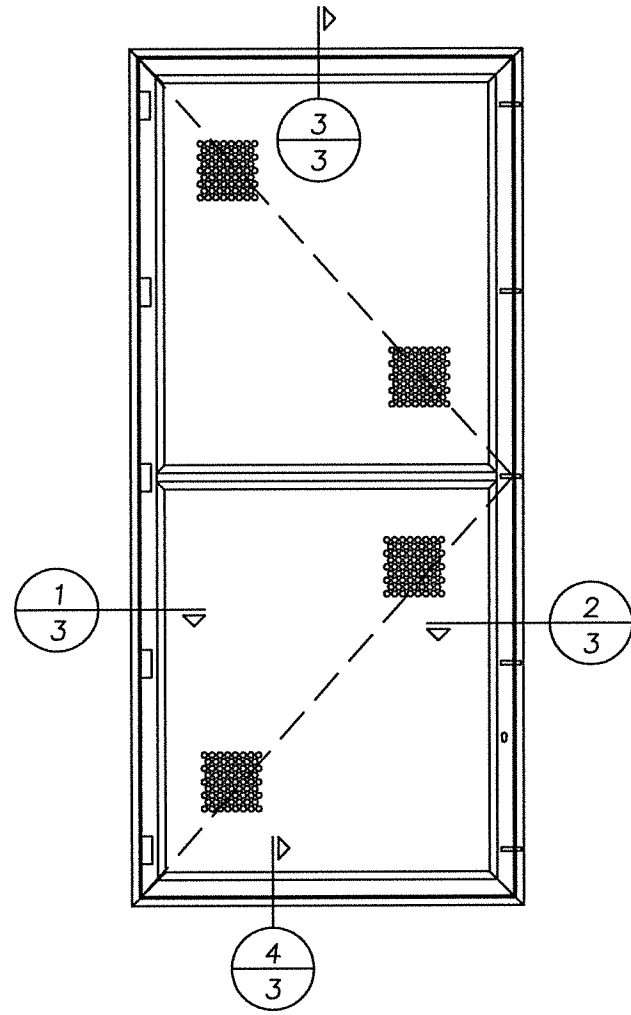

2 REVEAL MOUNT - STRIKE JAMB
3 LOCK REMOVED FOR CLARITY

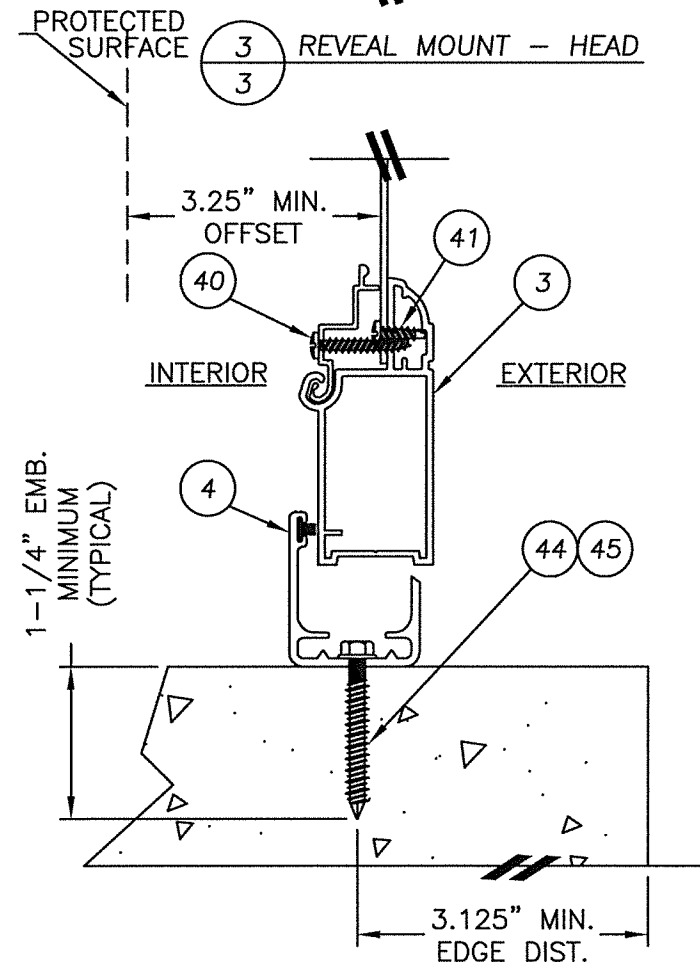

4 REVEAL MOUNT - BASE
3

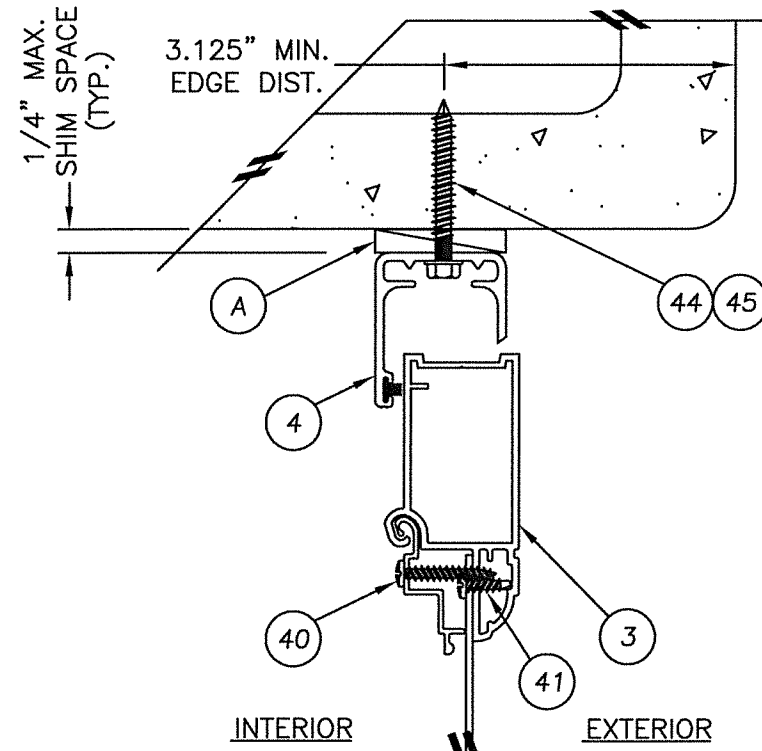

PROTECTED SURFACE 3 REVEAL MOUNT - HEAD
3

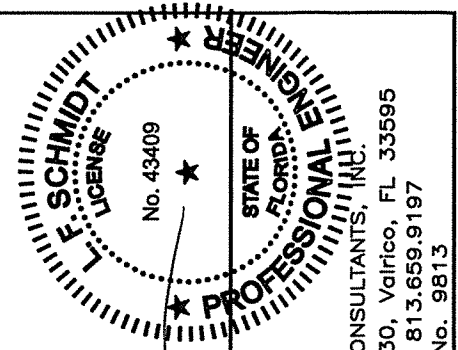

Documents Prepared By:
Lyndon F. Schmidt
P.E. No. 43409
R.W. BUILDING CONSULTANTS, INC.
P.O. Box 230, Vairico, FL 33595
Phone No.: 813.659.9197
FBPE C.A. No. 9813

PRODUCT:
KANE SCREENS
VAN GUARD II
ALUMINUM HURRICANE BARRIER
PART OR ASSEMBLY:
REVEAL MOUNT SECTIONS
MASONRY WALLS

NO.	DATE	BY	REVISIONS
2	9/26/17	JK	UPDATE TO 6TH ED. (2017) FBC
1	7/01/15	LFS	UPDATE TO 5th ED. (2014) FBC

DATE: 11/11/13
SCALE: N.T.S.
DWG. BY: JK
CHK. BY: LFS
DRAWING NO.: FL-10238.3
SHEET 3 OF 9

R:\Clients\Kane PERMANENTVA - Florida Product Approvals\FL-10238\C - Drawings\FL 10238 (2017)\FL-10238.3.dwg, 4.1

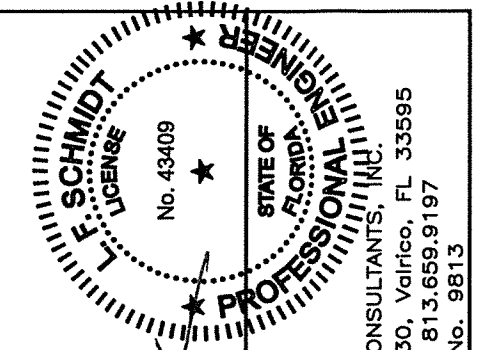
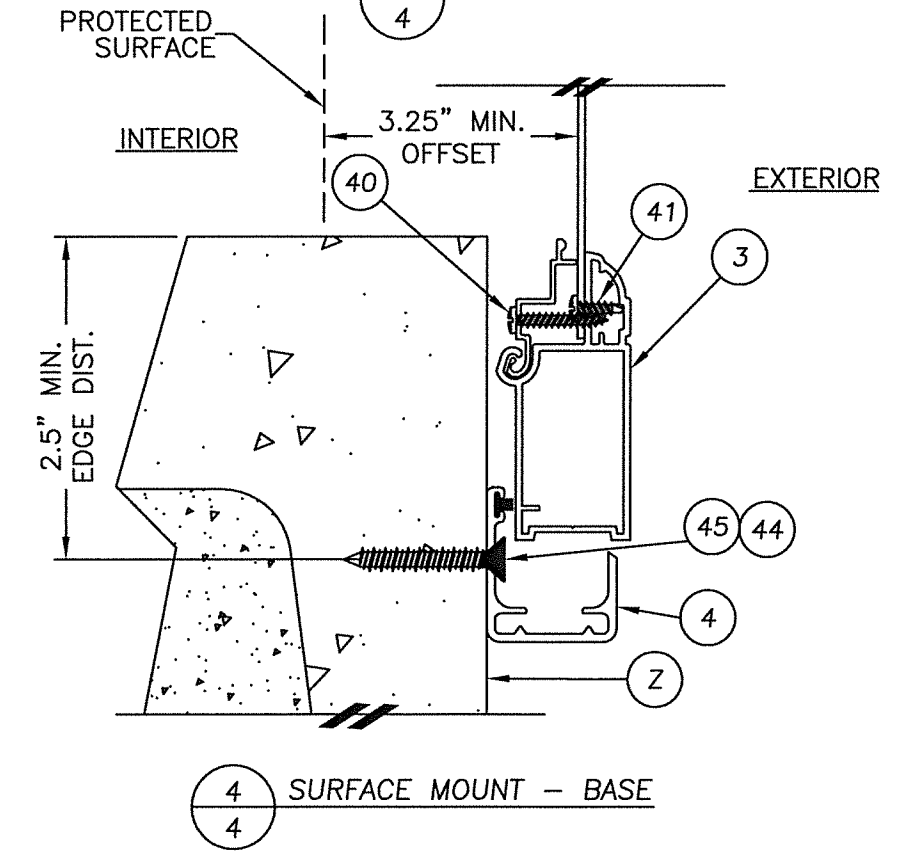
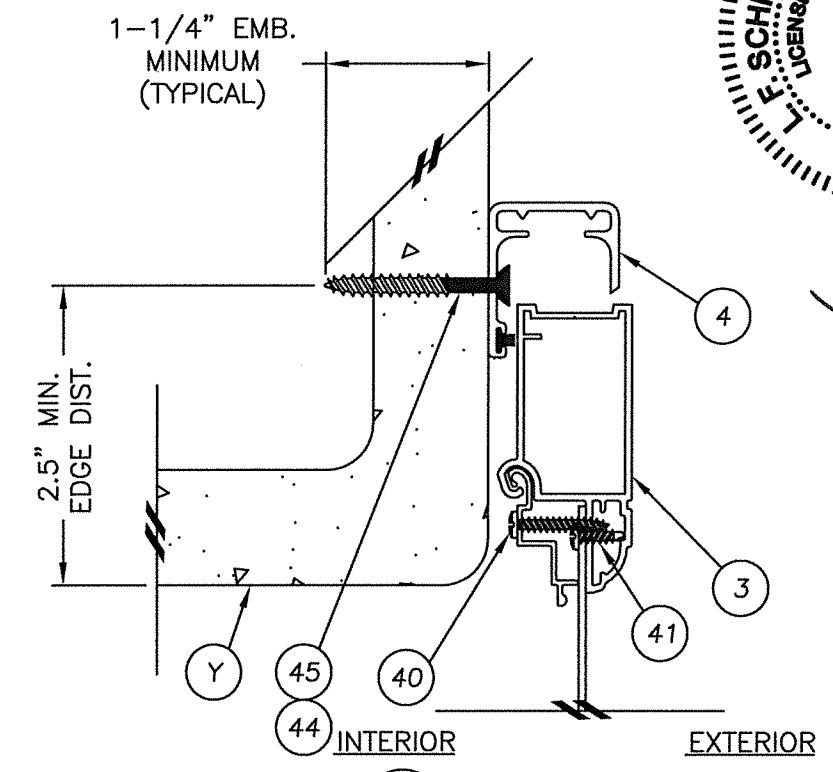
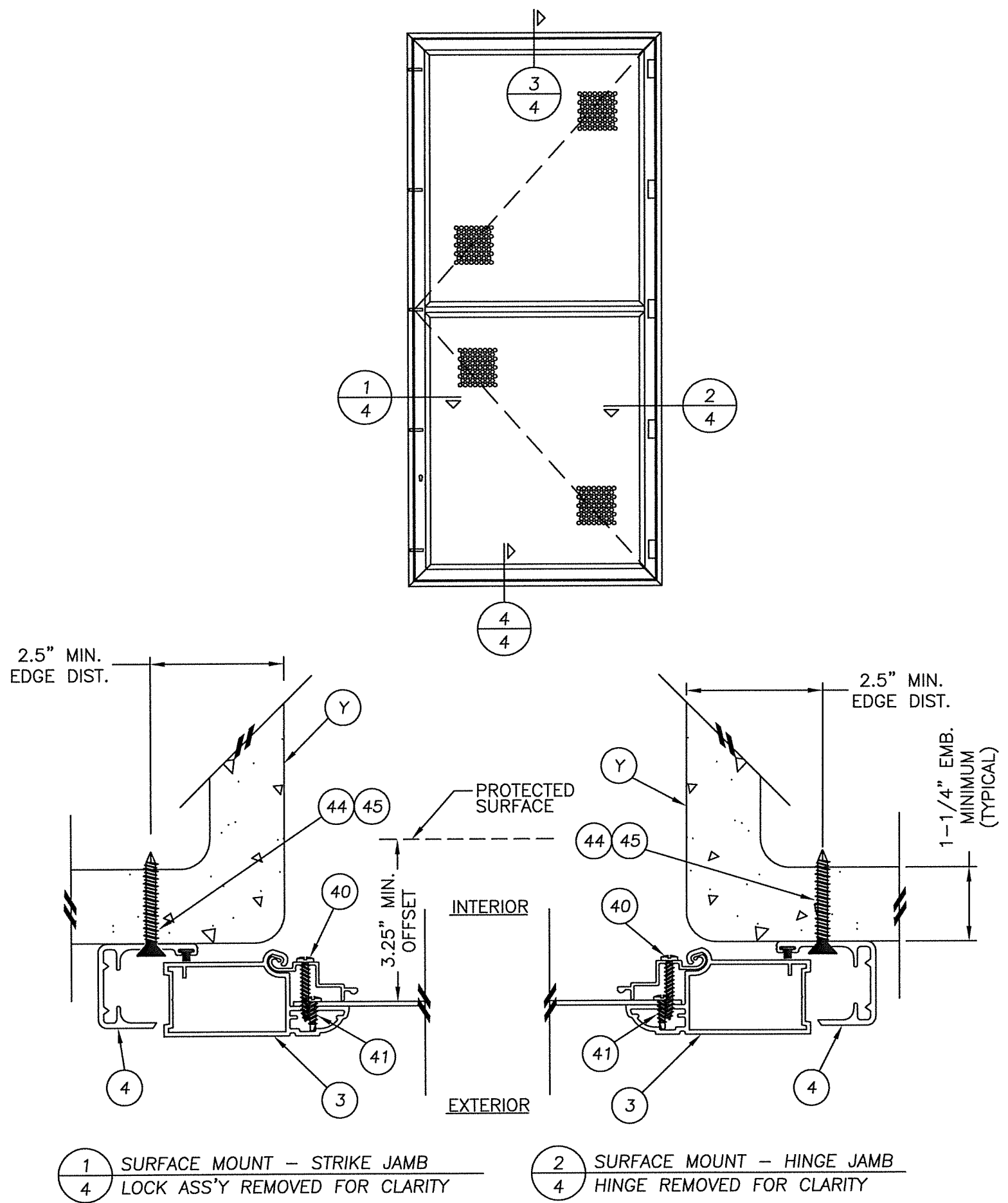

Documents Prepared By:
Lyndon F. Schmidt
P.E. No. 43409

R.W. BUILDING CONSULTANTS, INC.
P.O. Box 230, Valrico, FL 33595
Phone No.: 813.659.9197
FBPE C.A. No. 9813

PRODUCT:
KANE SCREENS
VAN GUARD II
ALUMINUM HURRICANE BARRIER
PART OR ASSEMBLY:
SURFACE MOUNT SECTIONS
MASONRY WALLS

NO.	DATE	BY
2	9/26/17	JK
1	7/01/15	LFS

DATE: 11/11/13
SCALE: N.T.S.
DWG. BY: JK
CHK. BY: LFS
DRAWING NO.: FL-10238.3
SHEET 4 OF 9

© 2013 R.W. BUILDING CONSULTANTS INC.

R:\Clients\Kane PERMANENTVA - Florida Product Approvals\FL-10238\C - Drawings\FL-10238 (2017)\FL-10238.3.dwg, 5.1

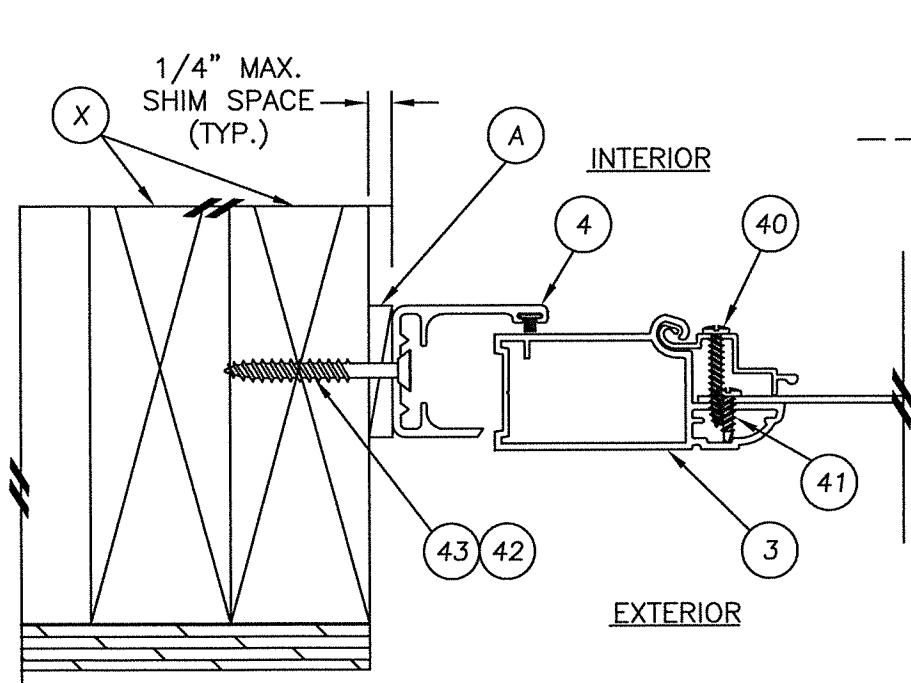
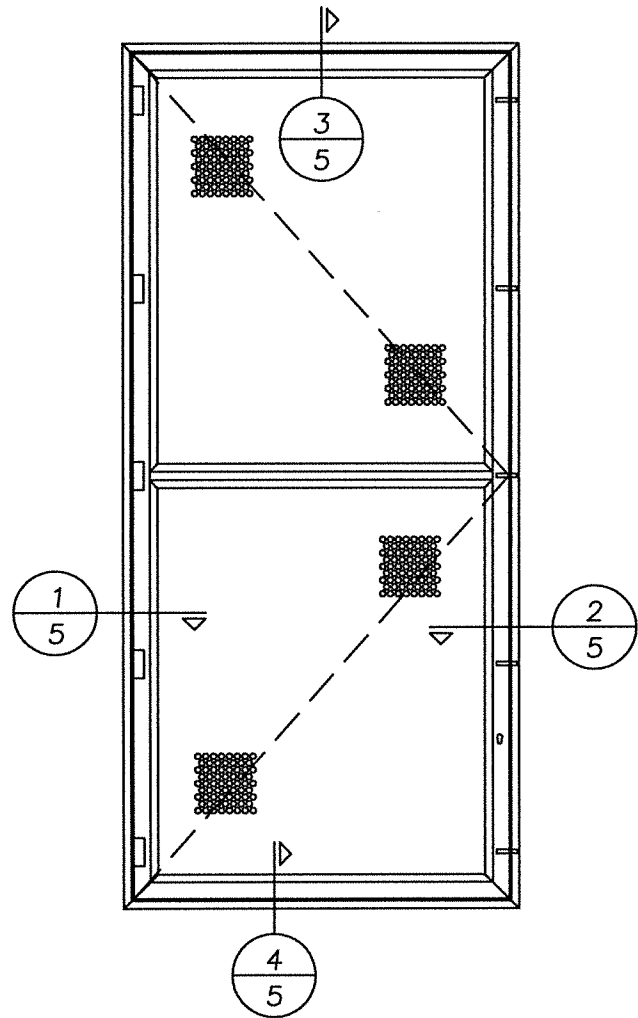

1 REVEAL MOUNT - HINGE JAMB
5 HINGE REMOVED FOR CLARITY

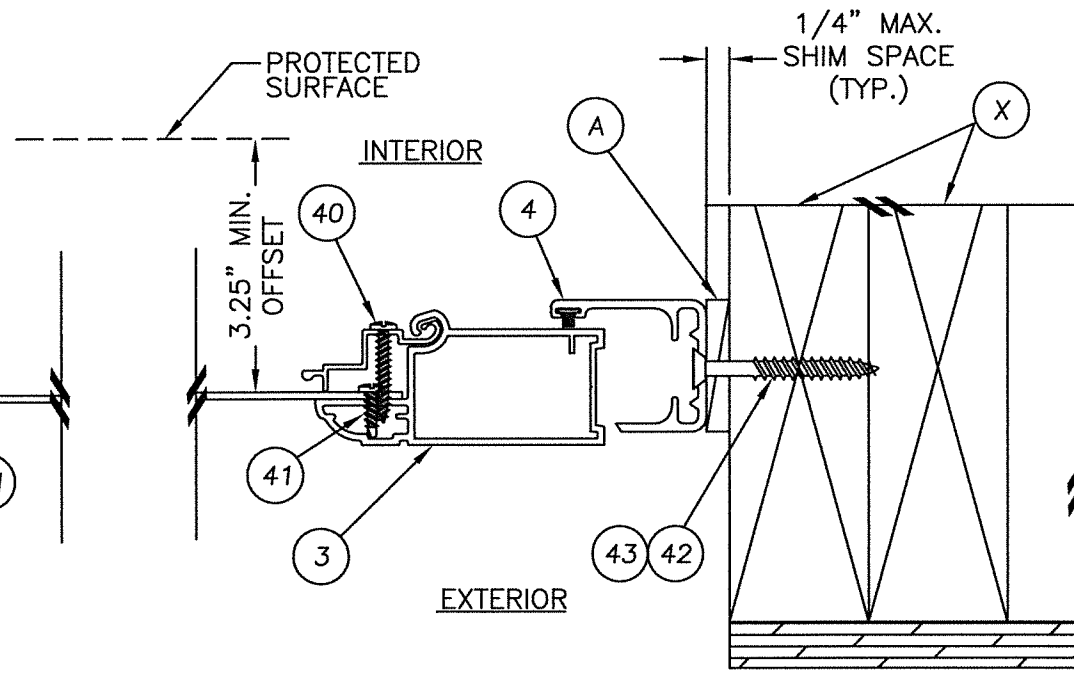

2 REVEAL MOUNT - STRIKE JAMB
5 LOCK REMOVED FOR CLARITY

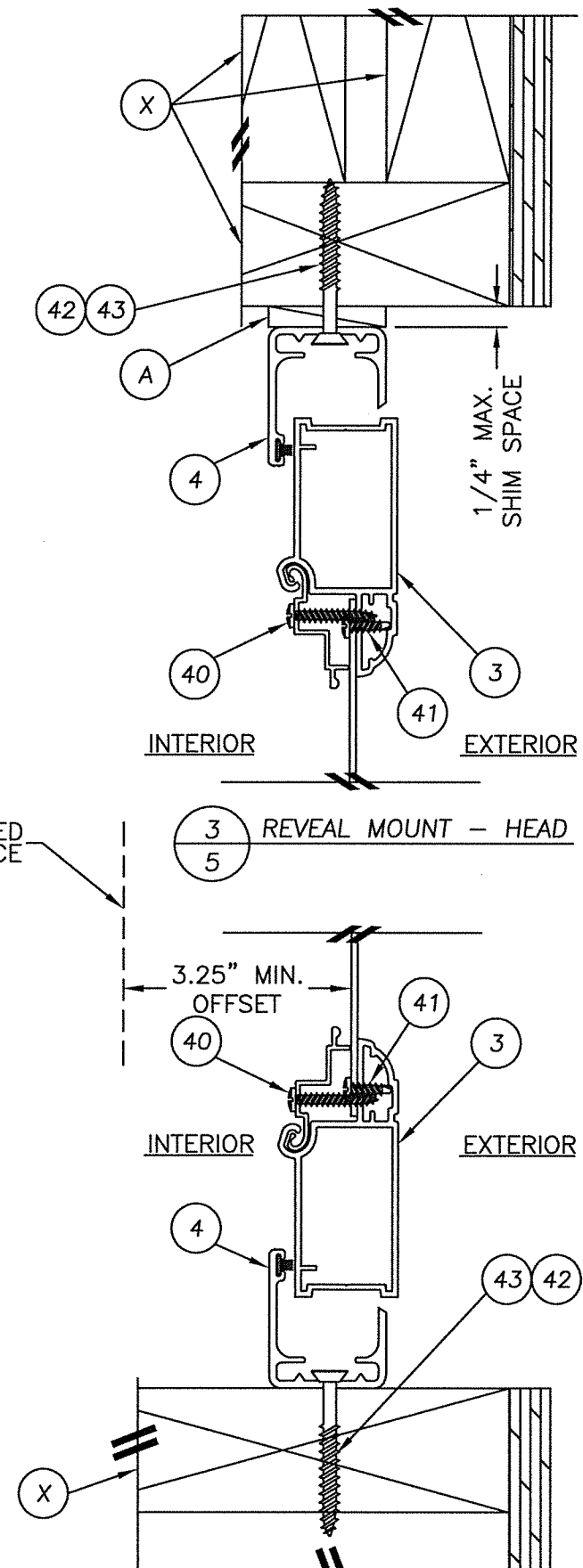

4 REVEAL MOUNT - BASE
5

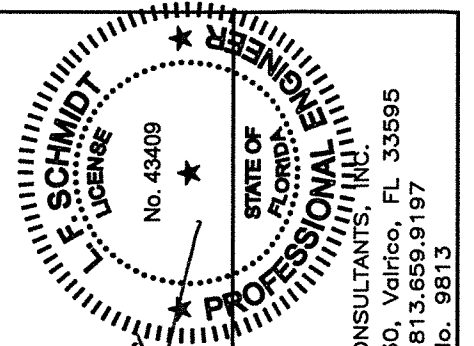

Documents Prepared By:
Lyndon F. Schmidt
P.E. No. 43409
10.3.17
R.W.
BUILDING CONSULTANTS, INC.
P.O. Box 230, Valrico, FL 33595
Phone No.: 813.659.9197
FBPE C.A. No. 9813

PRODUCT:
KANE SCREENS
VAN GUARD II
ALUMINUM HURRICANE BARRIER
PART OR ASSEMBLY:
REVEAL MOUNT SECTIONS
2X WOOD FRAMING

NO.	DATE	BY	REVISIONS
2	9/26/17	JK	UPDATE TO 6TH ED. (2017) FBC
1	7/01/15	LFS	UPDATE TO 5TH ED. (2014) FBC

DATE: 11/11/13
SCALE: N.T.S.
DWG. BY: JK
CHK. BY: LFS
DRAWING NO.: FL-10238.3
SHEET 5 OF 9

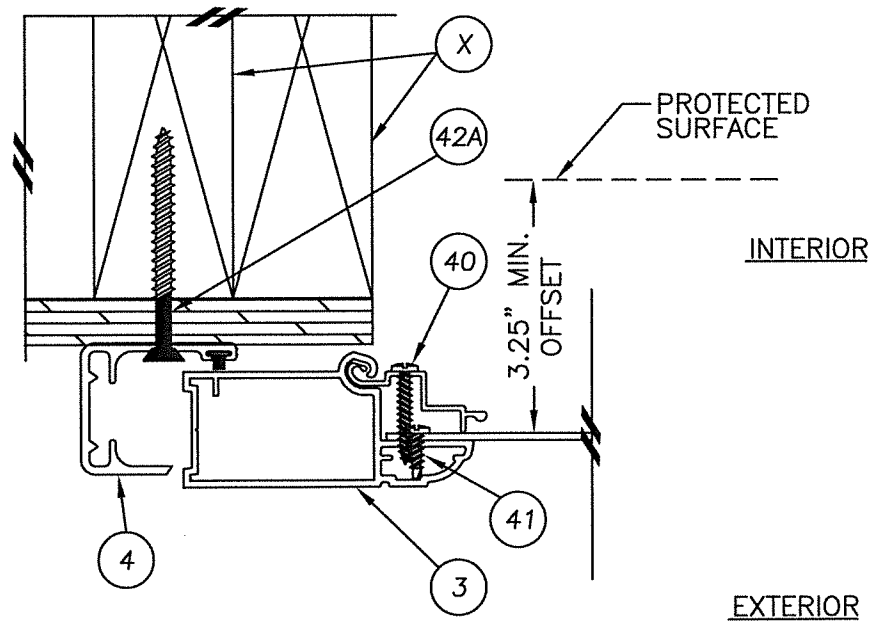
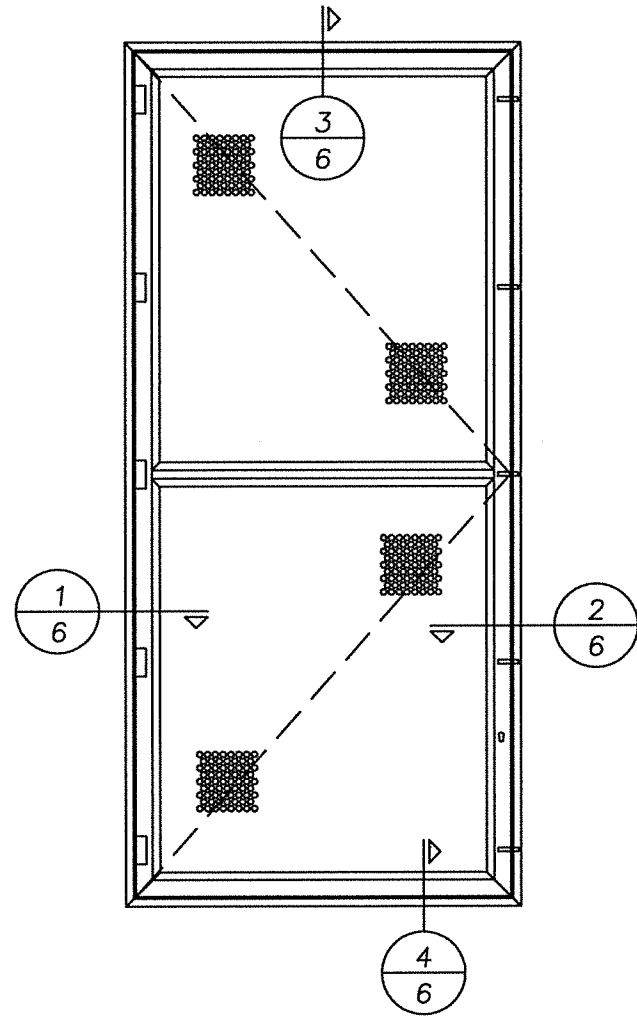

1 SURFACE MOUNT - HINGE JAMB
6 HINGE REMOVED FOR CLARITY

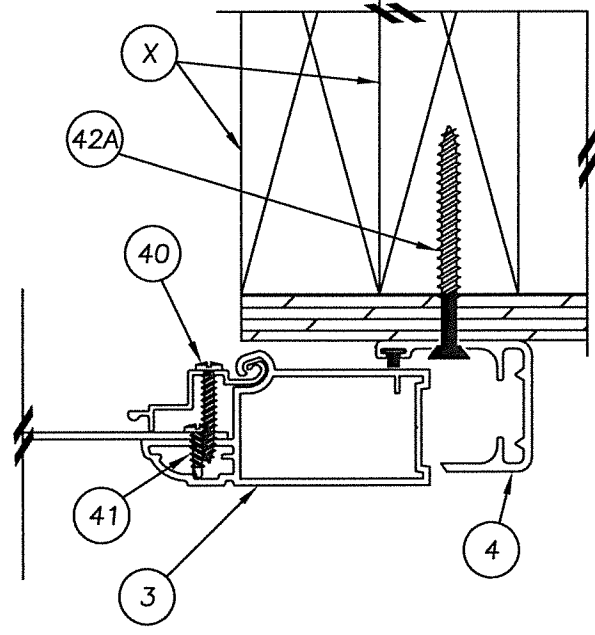

2 SURFACE MOUNT - STRIKE JAMB
6 LOCK REMOVED FOR CLARITY

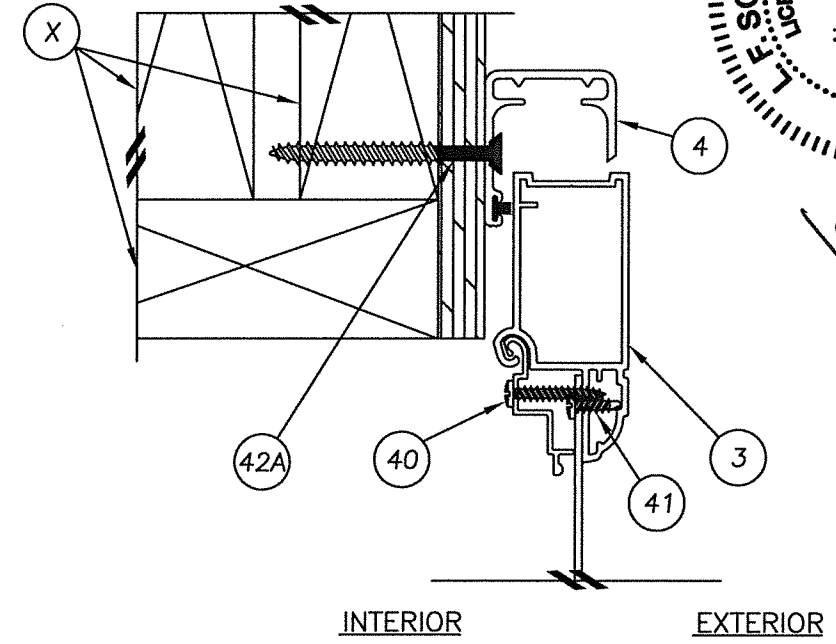

3 SURFACE MOUNT - HEAD
6

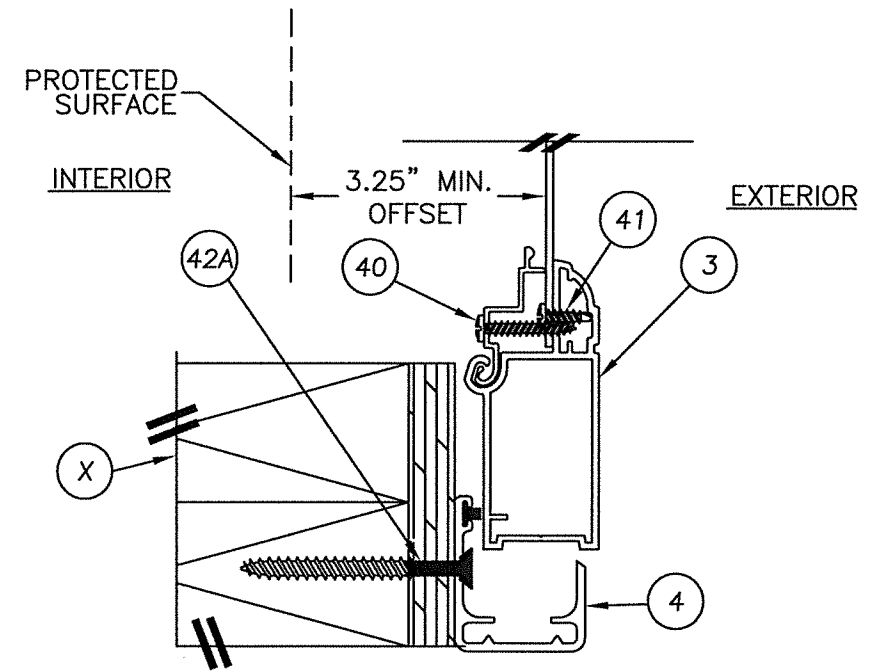

4 SURFACE MOUNT - BASE
6

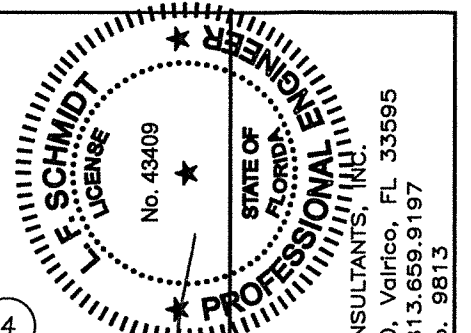

Documents Prepared By:
Lyndon F. Schmidt
P.E. No. 43409

R.W. BUILDING CONSULTANTS, INC.
P.O. Box 230, Valrico, FL 33595
Phone No.: 813.659.9197
FBPE C.A. No. 9813

PRODUCT:
KANE SCREENS
VAN GUARD II
ALUMINUM HURRICANE BARRIER
PART OR ASSEMBLY:
SURFACE MOUNT SECTIONS
2X WOOD FRAMING

NO.	DATE	BY
2	9/26/17	JK
1	7/01/15	LFS

DATE: 11/11/13
SCALE: N.T.S.
DWG. BY: JK
CHK. BY: LFS
DRAWING NO.: FL-10238.3
SHEET 6 OF 9

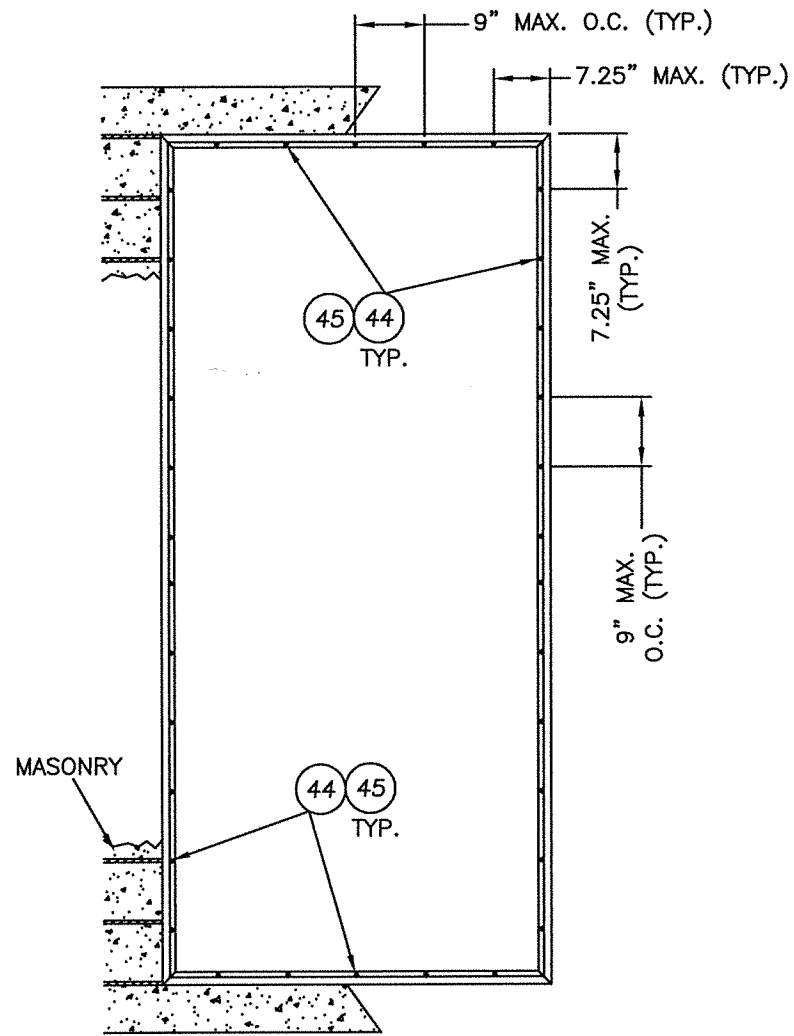

**SURFACE MOUNT
SUB-FRAME ANCHORING**

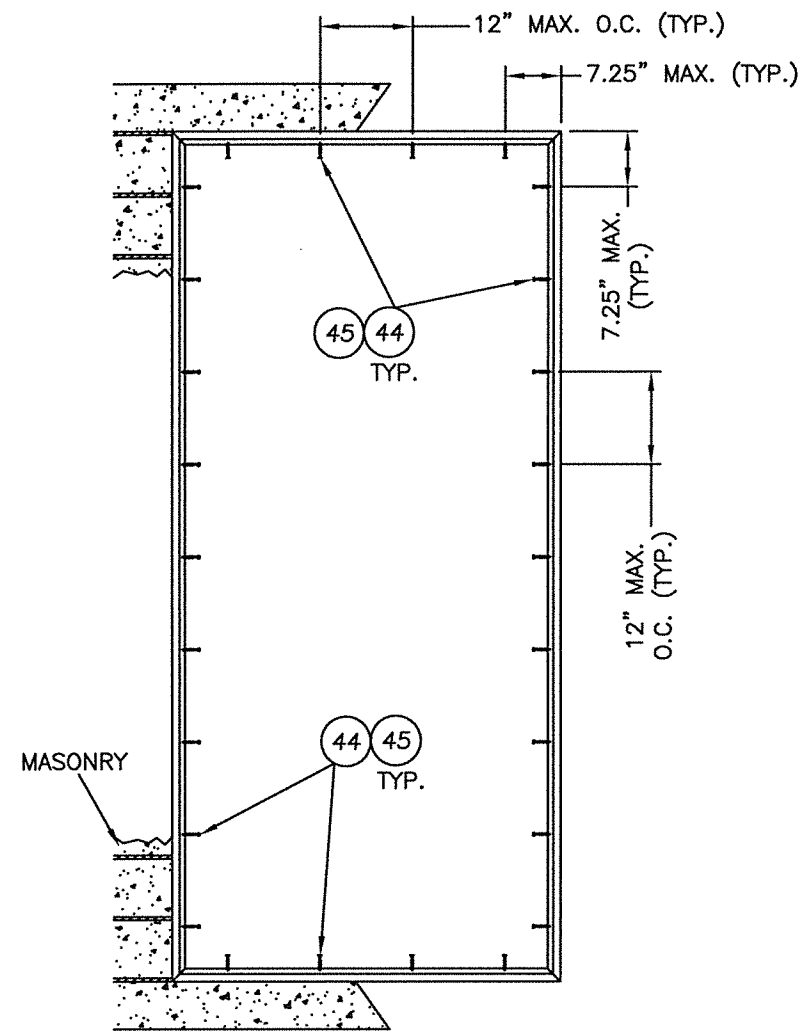

**REVEAL MOUNT
SUB-FRAME ANCHORING**

MASONRY ANCHORING

CONCRETE ANCHOR NOTES:

1. Substitution of equal concrete anchors from a different supplier may have different edge distance and center distance requirements.
2. Concrete anchor locations at the corners may be adjusted to maintain the min. edge distance to mortar joints. Concrete anchor locations noted as "MAX. ON CENTER" must be adjusted to maintain the min. edge distance to mortar joints, additional concrete anchors may be required to ensure the "MAX. ON CENTER" dimension are not exceeded.
3. Concrete anchor table:

ANCHOR TYPE	ANCHOR SIZE	MIN. EMBEDMENT	MIN. CLEARANCE TO MASONRY EDGE	MIN. CLEARANCE TO ADJACENT ANCHOR
ITW TAPCON®	1/4"	1-1/4"	2-1/2"	4"
ELCO ULTRACON®	1/4"	1-1/4"	2-1/2"	4"

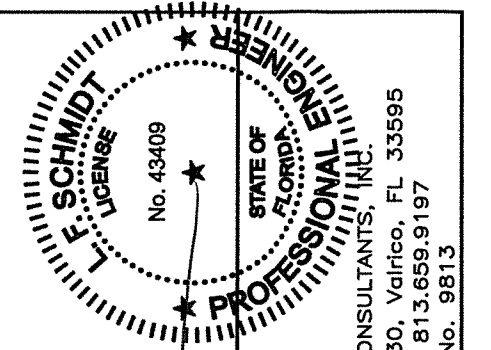

Documents Prepared By:
Lyndon F. Schmidt
P.E. No. 43409
16.3.17
R.W.
BUILDING CONSULTANTS, INC.
P.O. Box 230, Vairico, FL 33595
Phone No.: 813.659.9197
FBPE C.A. No. 9813

PRODUCT: KANE SCREENS
VAN GUARD II
ALUMINUM HURRICANE BARRIER
PART OR ASSEMBLY:
FRAME ANCHORING
MASONRY WALL

NO.	DATE	BY	REVISIONS
2	9/26/17	JK	UPDATE TO 6TH ED. (2017) FBC
1	7/01/15	LFS	UPDATE TO 5th ED. (2014) FBC

DATE: 11/11/13
SCALE: N.T.S.
DWG. BY: JK
CHK. BY: LFS
DRAWING NO.: FL-10238.3
SHEET 7 OF 9

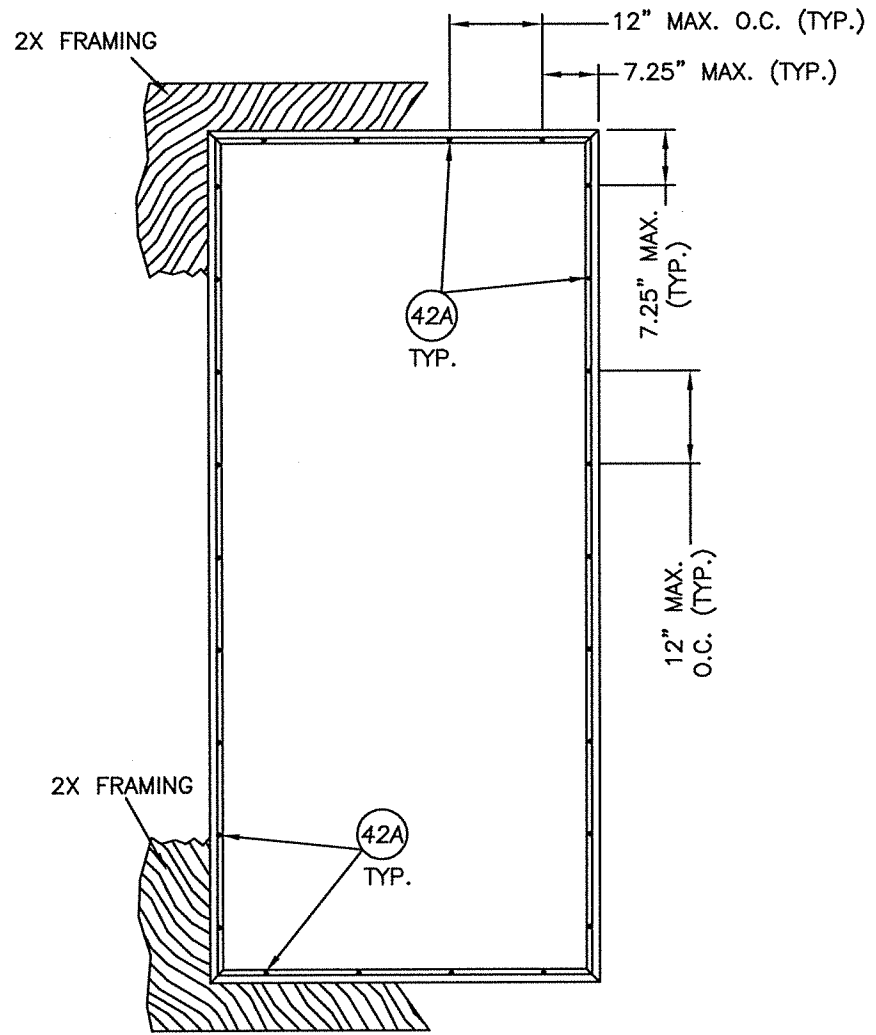

SURFACE MOUNT
SUB-FRAME ANCHORING

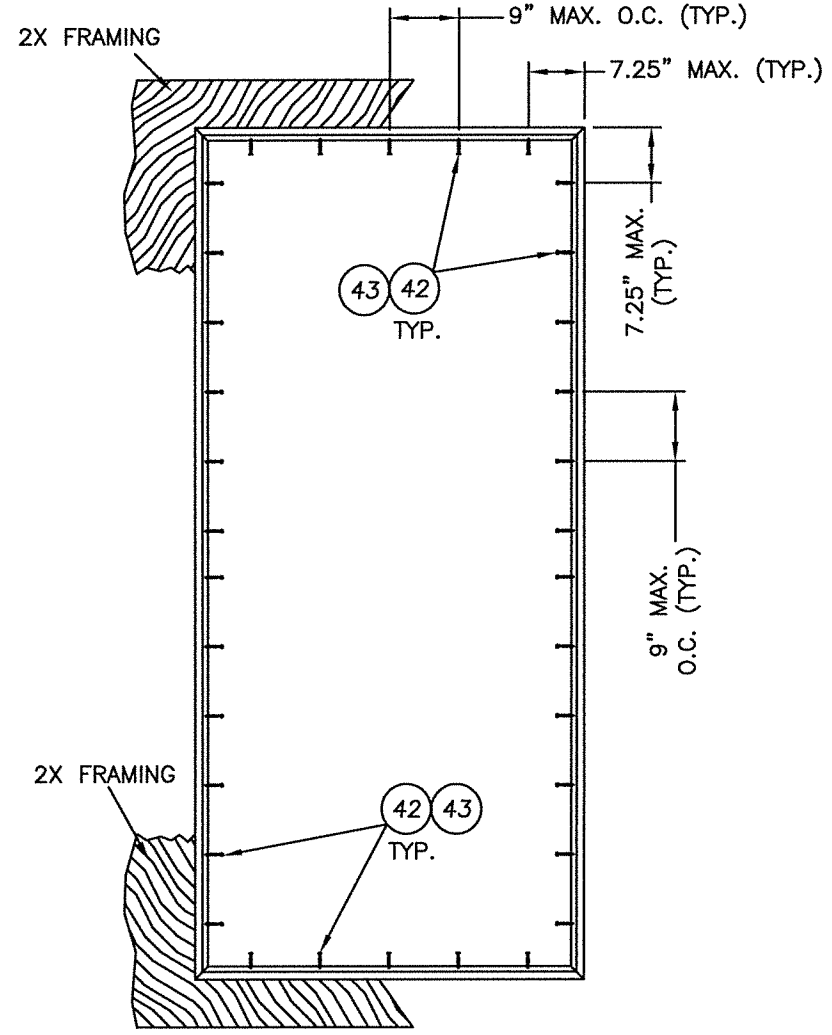

REVEAL MOUNT
SUB-FRAME ANCHORING

2X WOOD FRAME ANCHORING

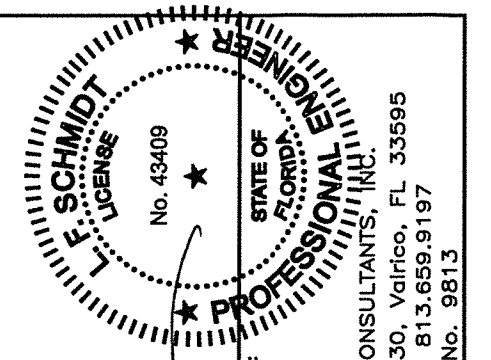

Documents Prepared By:
Lyndon F. Schmidt
P.E. No. 43409
RW BUILDING CONSULTANTS, INC.
P.O. Box 230, Valrico, FL 33595
Phone No.: 813.659.9197
FBPE C.A. No. 9813

PRODUCT: KANE SCREENS
VAN GUARD II
ALUMINUM HURRICANE BARRIER
PART OR ASSEMBLY:
FRAME ANCHORING
2X WOOD FRAMING

NO.	DATE	REVISIONS
2	9/26/17	UPDATE TO 6TH ED. (2017) FBC JK
1	7/01/15	UPDATE TO 5th ED. (2014) FBC LFS

DATE: 11/11/13
SCALE: N.T.S.
DWG. BY: JK
CHK. BY: LFS
DRAWING NO.:
FL-10238.3
SHEET 8 OF 9

BILL OF MATERIALS (ANCHOR)		
ITEM	DESCRIPTION	MATERIAL
S1	SCREEN DETAIL (GALVANNEALED STEEL)	STEEL
X	2X FRAMING (SG >= 0.55)	WOOD
Y	HOLLOW BLOCK CMU (ASTM C90)	CONCRETE
Z	CONCRETE MASONRY (3000 PSI MIN. - ACI 301)	CONCRETE
A	1/4" MAX. SHIM	WOOD
B	MAIN FRAME CORNER ANGLE WRAP	STEEL
3	MAIN FRAME 6063-T6	ALUMINUM
4	SUB FRAME 6063-T6	ALUMINUM
5	HORIZONTAL BRACE 6063-T6	ALUMINUM
6	MAINFRAME COVER 6063-T6	ALUMINUM
7	MAIN FRAME CORNER KEY 6063-T6	ALUMINUM
8	MAIN FRAME SECONDARY CORNER KEY 6063-T6	ALUMINUM
9	HORIZONTAL BRACE CORNER KEY 6063-T6	ALUMINUM
30	LOCK ASSEMBLY (KANE 107 BITT KEY LOCK w/ 1/2" DIA. BOLT)	STEEL
31	HINGE ASSEMBLY (TYPE 304 STAINLESS STEEL)	ST. STEEL
32	BOLT STRIKE PLATE (16 GA. STEEL)	STEEL
40	#8 X 1" SQ DRIVE PAN HEAD SMS	ST. STEEL
41	#8 X 1/2" SQ DRIVE PH TEK SCREW	ST. STEEL
42	#12 X 2" PFH WOOD SCREW (1-1/2" MIN. EMBEDMENT)	STEEL
42A	#12 X 2-1/2" PFH WOOD SCREW (1-3/4" MIN. EMBEDMENT)	STEEL
43	#12 X 2" PAN HEAD SMS (1-1/2" MIN. EMBEDMENT)	STEEL
44	1/4" X 1-3/4" HWH ELCO OR ITW CONCRETE SCREW	STEEL
45	1/4" X 1-3/4" PFH ELCO OR ITW CONCRETE SCREW	STEEL
47	#14 X 2-1/2" PFH WOOD SCREW (1-5/8" MIN. EMBEDMENT)	STEEL
48	#10-24 X 3/8" HWH-SLOTTED MS	ST. STEEL
49	#10-24 X 7/8" PPH MS	STEEL
50	#12-24 X 1-3/8" #3 SQ DRIVE (#4 DRILL PT.)	STEEL
51	#10-24 X 3/8" SQ DRIVE PH THREAD CUTTING SCREW	ST. STEEL
52	#10-24 X 1/4" PPH MS	ST. STEEL
53	STRIKE PLATE (13 GA. STEEL)	STEEL

1. WOOD SCREW INSTALLATION NOTES:
 Maintain a minimum 3/4" edge distance, 1" end distance, & 1" o.c. spacing of wood screws to prevent the splitting of wood.

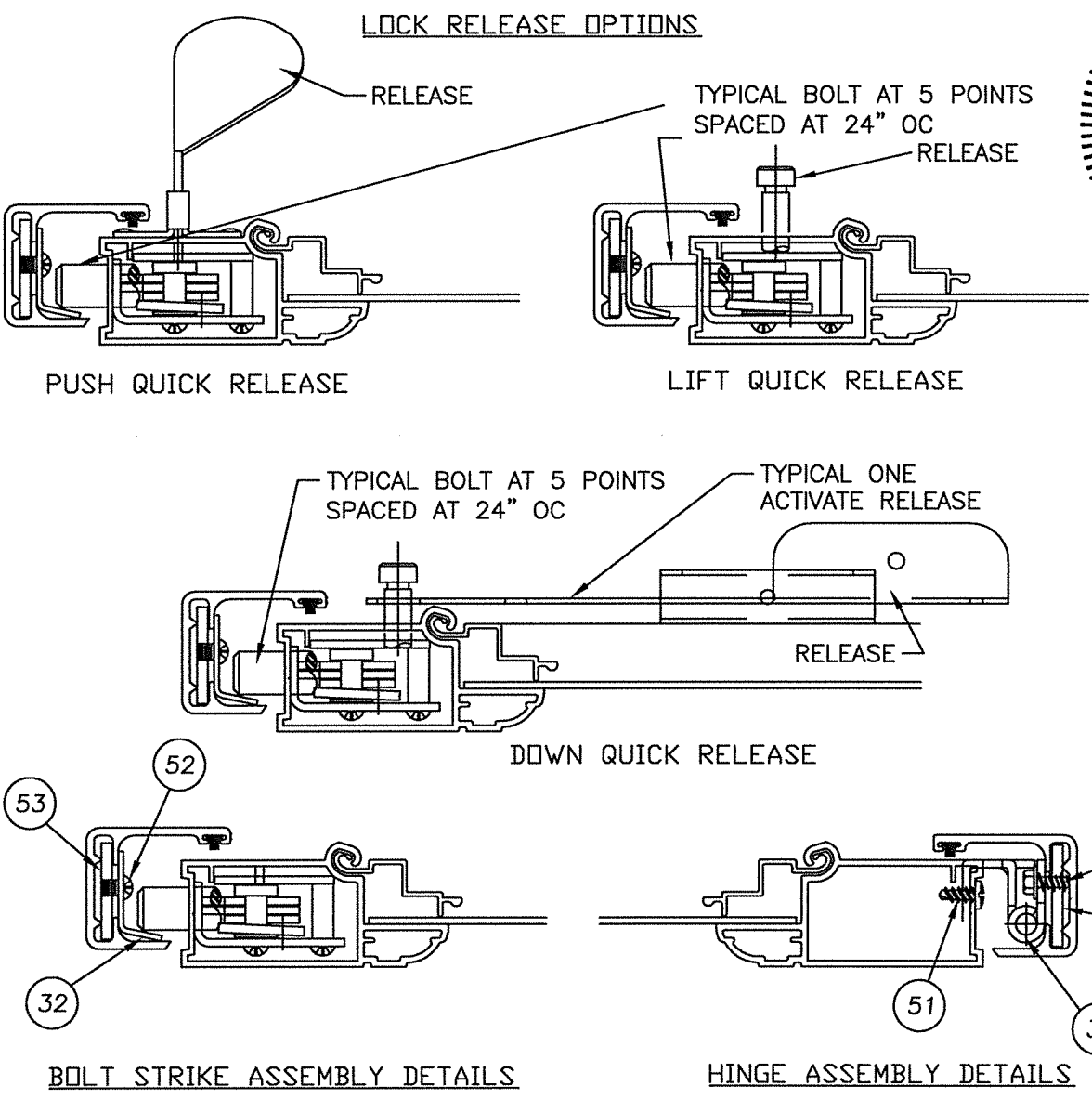
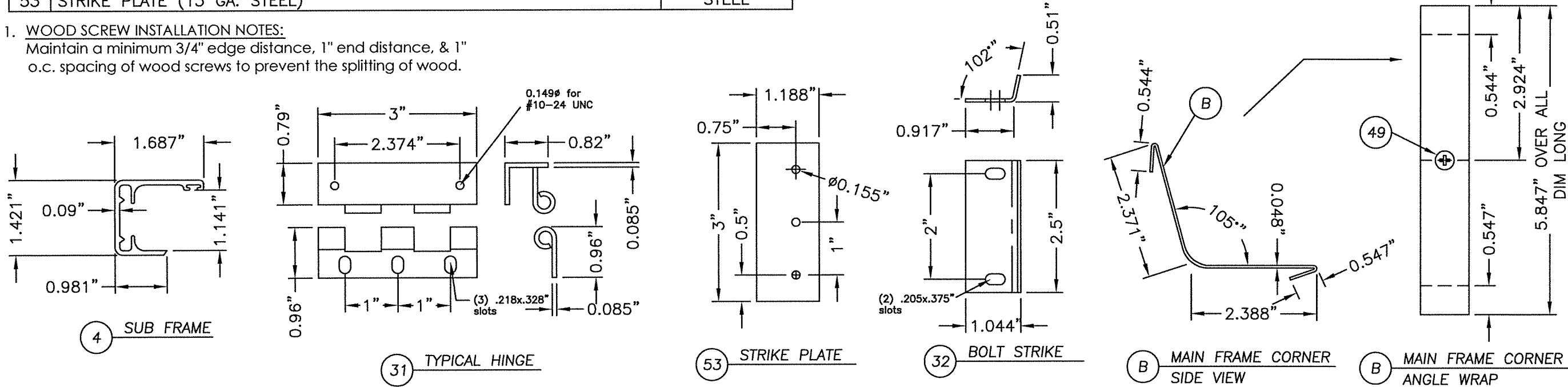

STATE OF FLORIDA PROFESSIONAL ENGINEER
 L. F. SCHMIDT
 No. 43409
 6.3.17

Documents Prepared By:
 Lyndon F. Schmidt
 P.E. No. 43409

R.W. BUILDING CONSULTANTS, INC.
 P.O. Box 230, Valrico, FL 33595
 Phone No.: 813.659.9197
 FBPE C.A. No. 9813

PRODUCT: KANE SCREENS VAN GUARD II ALUMINUM HURRICANE BARRIER PART OR ASSEMBLY: BILL OF MATERIALS, COMPONENTS & LOCK RELEASE OPTIONS

NO.	DATE	BY	REVISIONS
2	9/26/17	JK	UPDATE TO 6TH ED. (2017) FBC
1	7/01/15	LFS	UPDATE TO 5TH ED. (2014) FBC

DATE: 11/11/13
 SCALE: N.T.S.
 DWG. BY: JK
 CHK. BY: LFS
 DRAWING NO.: FL-10238.3
 SHEET 9 OF 9